

Product Catalogue

W.E. RESIDENTIAL SERIES

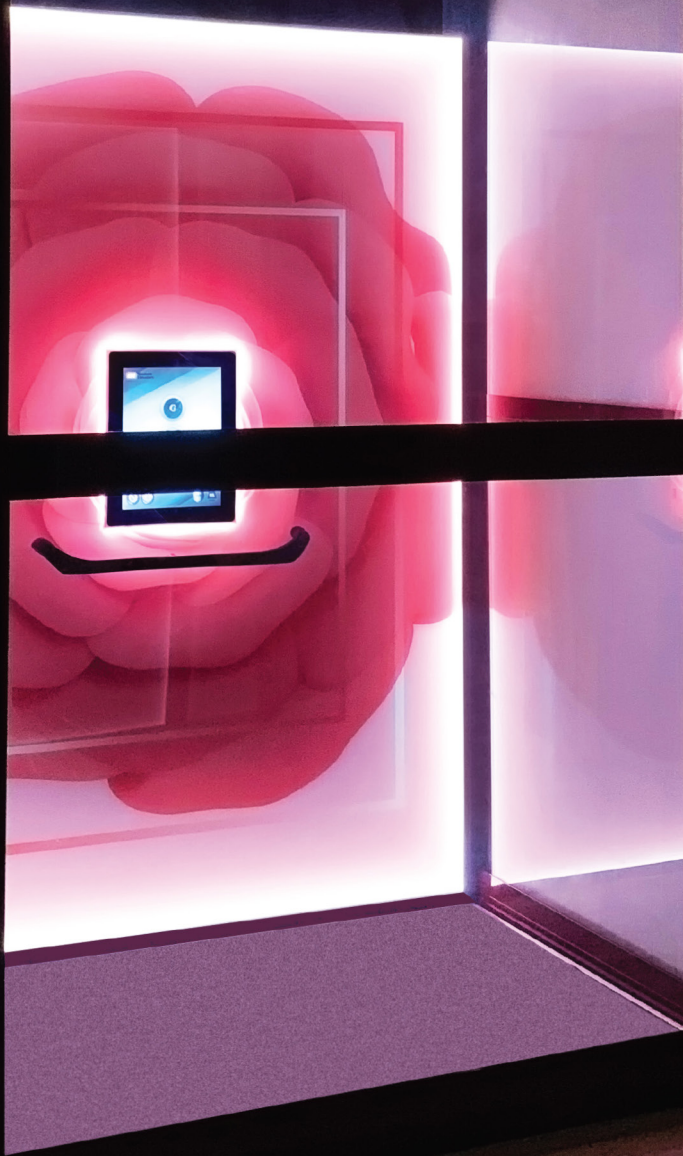

WE Western
Elevators

LIFTING YOU TO COMFORT

our story...

Western Elevators Sdn Bhd opened door for business in the year 2006. We are the pioneer for residential elevators in Malaysia. In the short 15 years in operation, we have installed and maintained over 1000 units of elevators all around Malaysia and Indonesia.

Over time, due to the increase in demand of residential elevators, Western Elevators Sdn Bhd aims to integrate residential elevators into people's daily life.

Understanding that every home carries a unique identity, Western Elevators Sdn Bhd offers wide selections of finishings for you to curate a personalised elevator you can truly call yours.

why western elevators

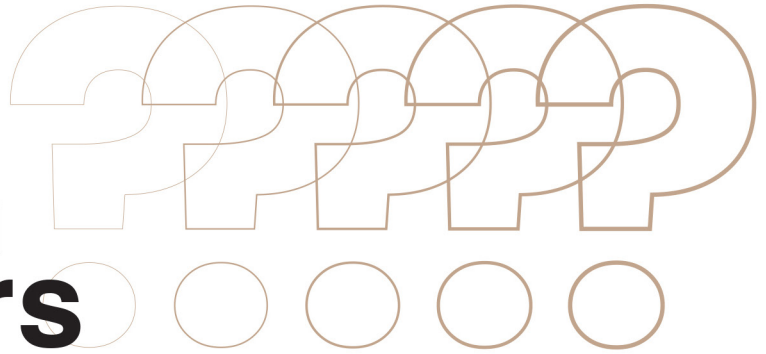

Our core beliefs of quality, safety, and integrity are what drives us to be the best in what we do.



Quality

Our elevators are built to be robust; constructed with style.



Safety

Our elevators not only excel in transporting our passengers, but also excel in protecting them from the unlikelihood of harm's way.



Integrity

We hold ourselves accountable to our customers for the installation, service and quality of our products every step along the way which guarantee the longevity of your comfort.



Warranty

- **5 years** full warranty.
- **5 years** free maintenance.
- **10 years** full warranty on screw/nut drive.

Having a Western Elevator in your living space will immerse you in an exclusive sense of ownership that will be your source of pride and joy.

Introducing to you W.E.Residential Series

Each and every elevator is tailored specially for you in terms of functionality and aesthetics, inside and out.

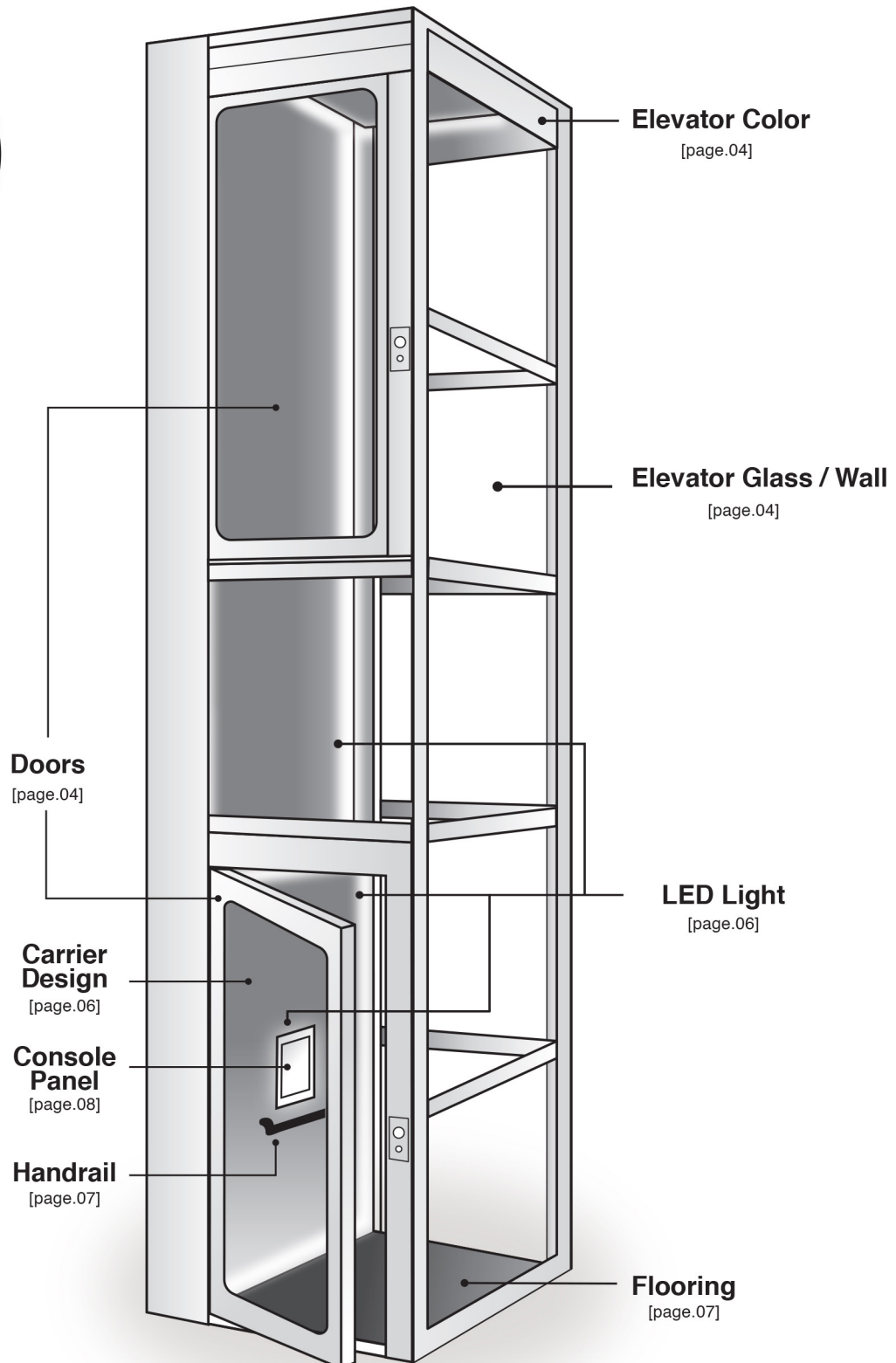

*Images are for illustration purposes only.

External Elevator Options

W.E. Residential Series are powder coated in 4 standard colors - Special formulated white, jet black, wine red and beige. The shaft finishing of the elevator is versatile as you can place the door on any side of the elevator. You may also choose the finishing of the shaft with fully covered, semi-glass or fully glass finishing.



Color: Jet Black
Full Glass

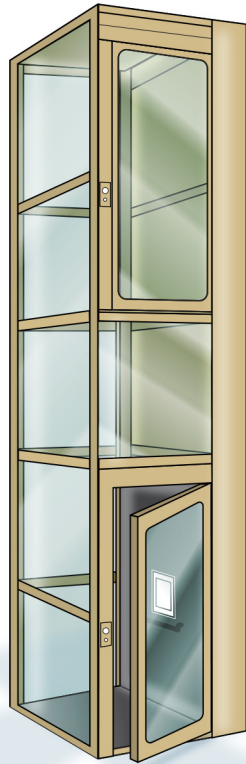

Color: Beige
3 Sides Glass

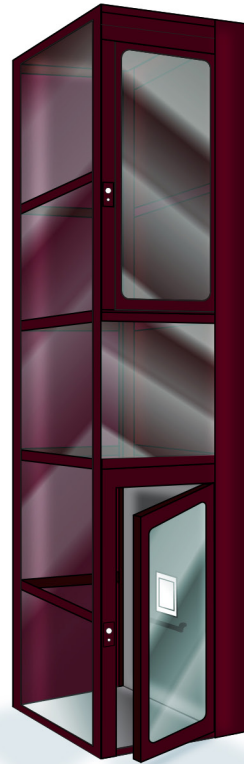

Color: Wine Red
2 Sides Glass

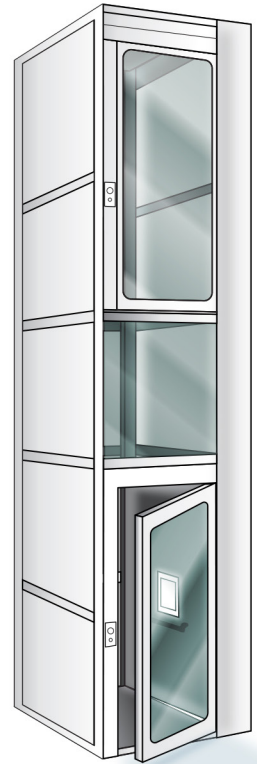

Color: White
1 Side Glass

Glass

3 different types of tempered laminated glass



Clear Glass



Tinted Glass



Frosted Glass

Landing Door

To complete your elevator, each floor comes with a full vision door. Each door is powder coated with the same color as the shaft you selected. Each door comes with a beautifully integrated door handle that enhances the aesthetics of your elevator .

*Images are for illustration purposes only.

Carrier Size Options

W.E. Residential Series is available in 2 standard sizes WE300 and WE400. Staying true to the core mission of W.E. Residential Series, we also provide custom-made shafts to suit your requirement.

External Size:
1300mm x 1300mm

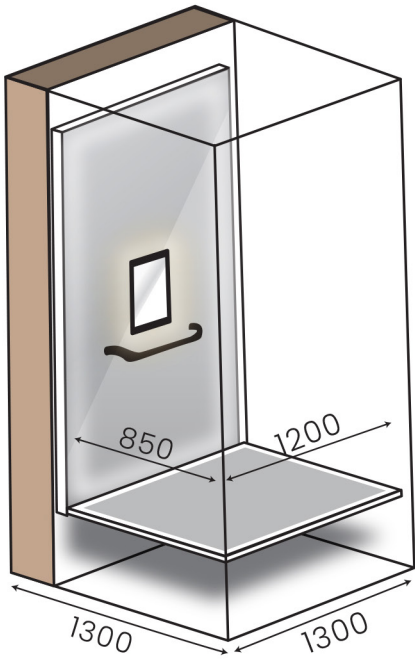

External Size:
1430mm x 1600mm

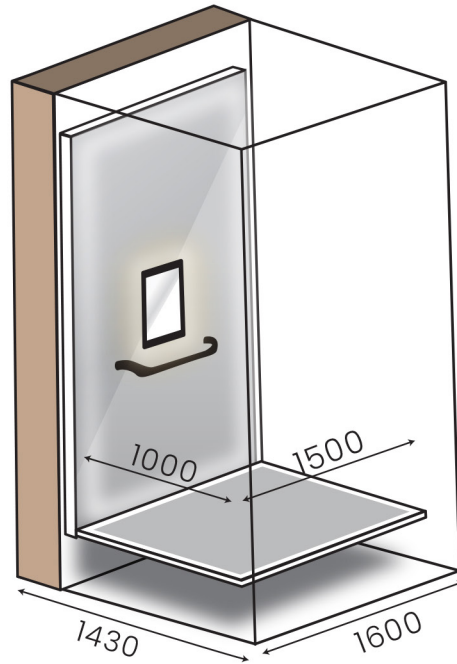

Internal Size:
850mm x 1200mm

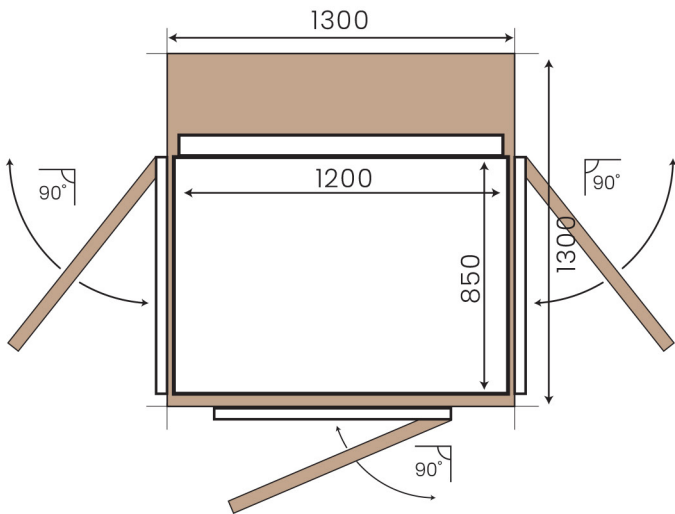

Model-WE300

Internal Size:
1000mm x 1500mm

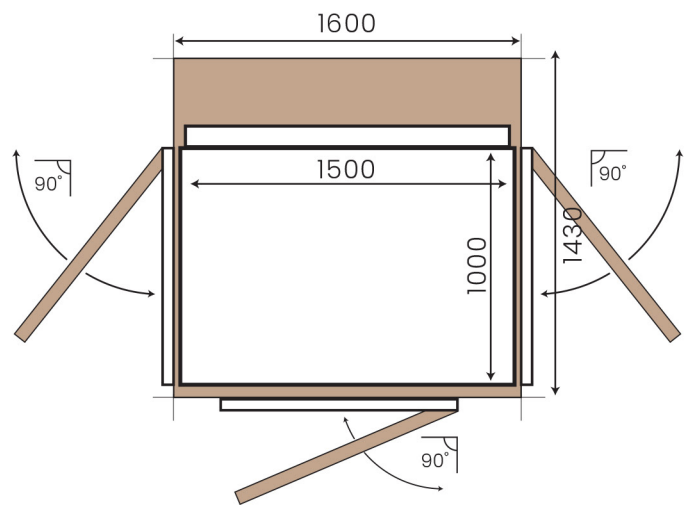

Model-WE400

*Images are for illustration purposes only.

Internal Carrier Options

The carrier consists of a L-Shaped carrier which is fully equipped with high quality materials; aluminium handrail electroplated for maximum corrosion resistance, wide selections of full height carrier designs to match your tastes, and a digitalised control operating panel to mobilise you everyday.



**8-CARRIER
DESIGNS FOR
SELECTION**

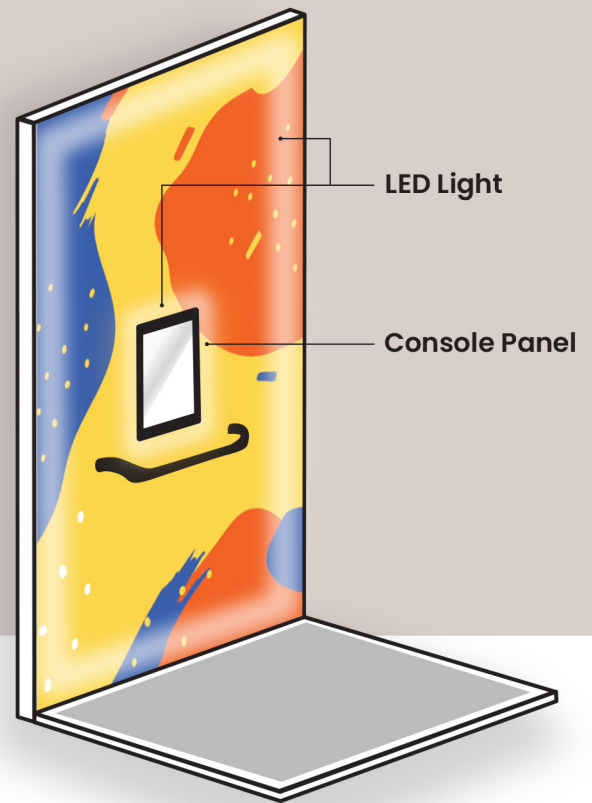

Carrier Designs

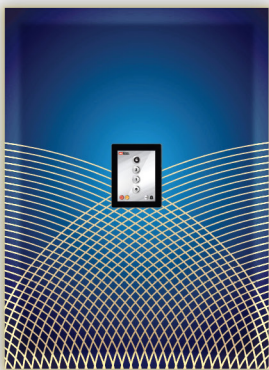

Horizon



Tessellate

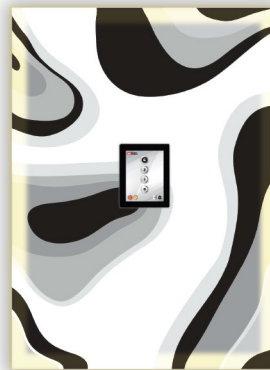

Marmo

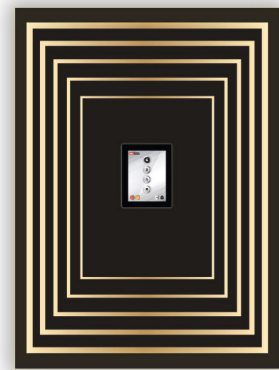

Jewel



Albus

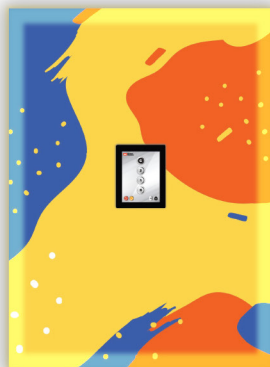

Matisse



Rosé

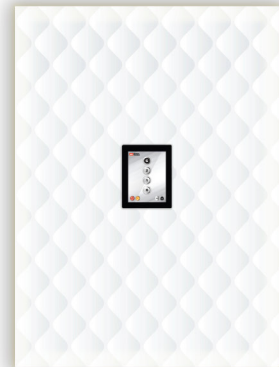

Plain Jane

*Images are for illustration purposes only.

Handrail

Each carrier comes with a carefully installed aluminium handrail. Each handrail is electroplated for maximum corrosion resistance to ensure the elevator's longevity and durability.



Flooring

Each carrier comes with anti-slip and anti-scratch flooring. The carefully selected designs will blend in seamlessly with any carrier designs or shaft finishing you selected.



Black Galaxy

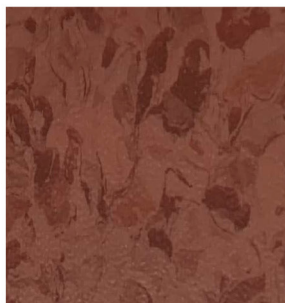

Mars



Milky Way



Grounded Earth

*Images are for illustration purposes only.

Control Panel Features

W.E. Residential Series is designed with the most sophisticated safety measures to ensure that they are user-friendly - **a worry-free experience.**

Landing Indicator

This indicates your current location level.

Destination Button

Button of the selected destination will light up as the elevator ascend or descend.

Emergency Stop Button

This emergency stop button is designed for use in an emergency situation.

Alarm Button

In the unlikely event that the elevator comes to an unintended stop, you may alarm dwelling members of your home.

Auto/Manual Button

User has two options, to descend or ascend during power failure. Auto button is the default mode that indicates the elevator will automatically descend to the nearest level during power failure. However, user may click on this button switching it into Manual Mode if user wishes to ascend to the nearest level.

Overloaded Icon

When the elevator is loaded with a heavier load than it is intended for, this button will lit up and the elevator will not operate.



Smart Console Panel

Each W.E. Residential Series comes equipped with a smart *state of the art* console panel. This system is able to display errors or fault in the elevator which will enable you to resolve such error quickly.



*Images are for illustration purposes only.



Safety Highlight

As safety is extremely important to us, W.E. Residential Series also equipped with **360° safety measures**.

→ Door Key Lock

Every elevator will come with a key switch which enables you to lock the elevator for safety purposes.

→ Safety Bars

Safety bars are installed across all edges of the carrier, stopping immediately if an object gets caught in one of the bars.

→ Interlock System

Doors on all levels will be locked with interlock system when elevator is in use.

→ Self-Rescue Mechanism

During power failure, elevator carrier will automatically descent to the nearest level and the landing door of the final destination will be unlocked.

→ Travel Accuracy

Over and under travel safety switch to ensure that the elevator travels within the permissible traveling distance.

→ Others

- Overload Detection
- Audible Alarm
- Emergency Lighting
- Safety Nut With Electric Switch
- Emergency Door Key
- Emergency Stop Button

*Images are for illustration purposes only.

Product Summary

Having your elevator installed is a straightforward process. The details and minimum requirements for a seamless installation are listed below:

Installation Environment	Indoor or Outdoor
Drive System	Screw and Nut Driven
Travel Height	Up to 6 stops
Top Height	min. 2400mm
Pit Requirement	50mm or install directly on the floor with a ramp
Destination and Call Button	Automatic one touch control system
Rated Speed	0.15m/s or 9m/m
Electrical Requirements	3ph 415v 16A 5 core

Carrier Size	WE 300	WE 400
Rated Load	300 kg	400 kg
Structural Opening	1300 x 1300mm	1430 x 1600mm
Carrier Size	850 x 1200mm	1000 x 1500mm



LIFTING YOU TO COMFORT







SCAN HERE TO
OUR WEBSITE

sales
person



more
info

 **Western Elevators Sdn Bhd** (948472-U)
No 12A, Jalan 17/1, Seksyen 17,
Petaling Jaya, 46400, Selangor.
 sales@westernelevators.com.my
 +603-7955 0088, 7651 7896
 www.westernelevators.com.my